

G5 DUAL THROW SERIES UNIT COOLER



CAPACITY

DTM - Medium Temperature: 5.9kW - 86.7kW

Effective Air Throw: 14.4m - 29.2m

G5

DUAL THROW SERIES UNIT COOLER

DTM

General Features

Eden G5 Dual Throw Unit Cooler is specially designed for process chiller room, enoki mushroom breeding and other specific applications using the forced draught air flow for better air distribution.

Eden coils are designed with the Latest Smart Circuitry. It allows maximum mass flow rate of refrigerant to be evenly distributed throughout the evaporator, maximizing coil efficiency thus providing higher efficiency and capacity with a smaller physical unit cooler dimension.

Eden coils use copper Inner Groove Tubes (IGT) that increases the internal coil surfaces whilst having a low oil film coefficient thus providing higher efficiencies and capacities. These copper tubes are in accordance with JIS-C1220T.

Fins are produced from high grade Aluminium (Aluminium Association - AA1100 Standard) with Double Sine Wave Pattern and Rippled Fin Edges for maximum fin surface and higher heat transfer efficiency.

Fan Motors used in all models are high quality fan motors, fitted with thermistor motor protection and conform to DIN 40050 safety standards. Fan motors are of the highest quality offered in the industry ensuring long life and durability for both high and low temperature applications.

Casing is made from high quality powder coated Aluminium, according to AA1100 Standards.

Electrical junction box(es) are 3mm thick ABS, IP56 protection rating with flame class V-0 and are mounted internally. Side panels on both ends are hinged allow for easy access to junction box(es) and service of components.

Eden G5 Dual Throw Unit Cooler can also be applied with most new generation refrigerants (except CO₂ & NH₃). All Capacity Ratings in this document are thermally guaranteed by Eden and tested in accordance to ASHRAE dry box standards.

Eden G5 Dual Throw Unit Cooler comes with Quality Assurance as they are designed, manufactured and tested at our factory with ISO9001 certification. It also comes with a One (1) Year Warranty against quality & manufacturing defects (Terms and conditions apply).





Options

- a** Copper-Fins coil
- b** Epoxy-Coated Aluminum Fin Coil (Only on large volume orders)
- c** Passivated Corrosion Protection for All Aluminum Fin Products
- d** Stainless Steel Casing
- e** German Fan Motors
- f** Insulated Drip Tray

Nomenclature

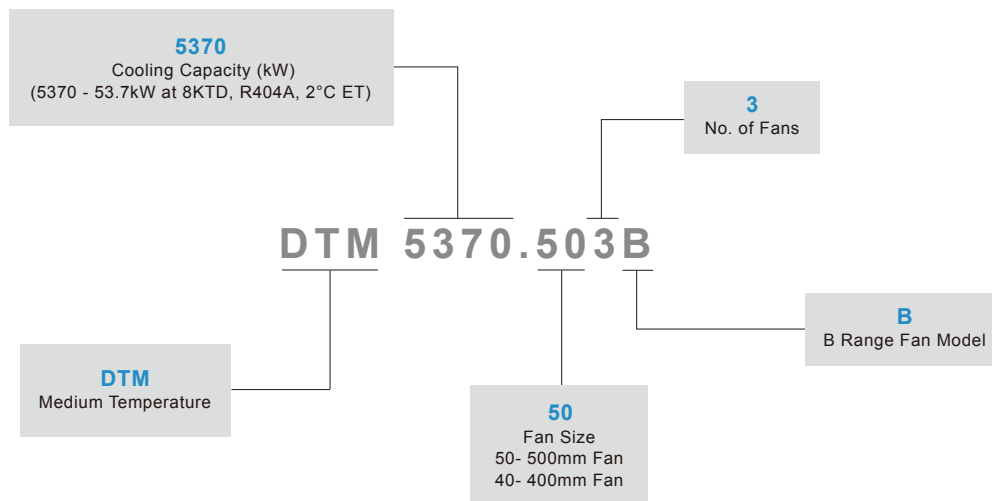

Technical Data

DTM - Medium Temperature Unit Cooler

Air Defrost 6FPI (4.23mm), Room Temperature +3°C / +10°C

Model	Capacity R404A / R507				No. of Fans 400mm	Fan Data						
	ASHRAE ET=-5°C, RT=3°C	ASHRAE ET=2°C, RT=10°C	EUROVENT SC1* ET=0°C, RT=10°C	EUROVENT SC2* ET=-8°C, RT=0°C		Fan Motor			Fan Speed	Air Flow		Air Throw** (m)
	Watts (8KTD)	Watts (8KTD)	Watts (10KTD)	Watts (8KTD)		(V/Ph/Hz)	(Watts)	(Amps)	(rpm)	(l/s)	(m³/h)	
DTM 0590.401B	5,000	5,900	8,500	5,500	1	400/3/50	190	0.5	1,350	770	2,772	2 x 7.4
DTM 0880.401B	7,400	8,800	12,600	8,100	1	400/3/50	190	0.5	1,350	760	2,736	2 x 7.2
DTM 1150.402B	9,700	11,500	16,500	10,600	2	400/3/50	380	1.0	1,350	1,560	5,616	2 x 7.9
DTM 1450.402B	12,300	14,500	20,900	13,400	2	400/3/50	380	1.0	1,350	1,540	5,544	2 x 7.8
DTM 1990.402B	16,900	19,900	28,600	18,400	2	400/3/50	380	1.0	1,350	1,510	5,436	2 x 7.6
DTM 2250.403B	19,000	22,500	32,300	20,800	3	400/3/50	570	1.5	1,350	2,350	8,460	2 x 8.4
DTM 3120.403B	26,400	31,200	44,800	28,800	3	400/3/50	570	1.5	1,350	2,290	8,244	2 x 8.2
DTM 3830.404B	32,500	38,300	55,100	35,500	4	400/3/50	760	2.0	1,350	3,090	11,124	2 x 8.9
DTM 4280.404B	36,300	42,800	61,600	39,700	4	400/3/50	760	2.0	1,350	3,050	10,980	2 x 8.8

Model	Capacity R404A / R507				No. of Fans 500mm	Fan Data						
	ASHRAE ET=-5°C, RT=3°C	ASHRAE ET=2°C, RT=10°C	EUROVENT SC1* ET=0°C, RT=10°C	EUROVENT SC2* ET=-8°C, RT=0°C		Fan Motor			Fan Speed	Air Flow		Air Throw** (m)
	Watts (8KTD)	Watts (8KTD)	Watts (10KTD)	Watts (8KTD)		(V/Ph/Hz)	(Watts)	(Amps)	(rpm)	(l/s)	(m³/h)	
DTM 1760.501B	14,900	17,600	25,300	16,300	1	400/3/50	750	1.5	1,350	1,900	6,840	2 x 10.6
DTM 2650.502B	22,500	26,500	38,100	24,500	2	400/3/50	1,500	3.0	1,350	3,780	13,608	2 x 12.6
DTM 3250.502B	27,500	32,500	46,600	30,000	2	400/3/50	1,500	3.0	1,350	3,670	13,212	2 x 12.6
DTM 3770.502B	31,900	37,700	54,200	34,900	2	400/3/50	1,500	3.0	1,350	3,540	12,744	2 x 12.6
DTM 4520.503B	38,300	45,200	64,900	41,800	3	400/3/50	2,250	4.5	1,350	5,500	19,800	2 x 13.5
DTM 5370.503B	45,500	53,700	77,200	49,700	3	400/3/50	2,250	4.5	1,350	5,330	19,188	2 x 13.1
DTM 6170.504B	52,300	61,700	88,800	57,200	4	400/3/50	3,000	6.0	1,350	7,280	26,208	2 x 14.6
DTM 8670.504B	73,500	86,700	124,700	80,300	4	400/3/50	3,000	6.0	1,350	6,980	25,128	2 x 13.7

Capacity Ratings & Conditions

All Eden Heat Exchangers are tested in Accordance to ASHRAE Dry Box Standard (Recommended for Asia Usage)

* **EUROVENT Data is used for Comparison Purposes**

* EUROVENT Data is based on **SC1/SC2 Nominal Capacity**

SC1 Condition - Air Inlet Temperature = +10°C and Evaporating Temperature = 0°C

SC2 Condition - Air Inlet Temperature = +0°C and Evaporating Temperature = -8°C

** Air Throw indicated is the distance from the unit to the further point where an air velocity of 0.5m/s can still be measured

Technical Data

DTM - Medium Temperature Unit Cooler

Air Defrost 6FPI (4.23mm), Room Temperature +3°C / +10°C

Model	Connection Details			Dimensional Details (mm)										Weight (Kg)*	
	Connection (mm)			A	B	H	H1	H2	C	W	L	H2*	W*		L*
	Liquid	Suction	Drain Pipe												
DTM 0590.401B	12.7	22.2	25.4	585	-	365	415	473	982	1,138	903	658	1,288	1,053	44
DTM 0880.401B	12.7	28.6	25.4	585	-	365	415	473	982	1,138	903	658	1,288	1,053	49
DTM 1150.402B	12.7	28.6	25.4	1,147	573.5	365	415	473	982	1,138	1,465	658	1,288	1,615	72
DTM 1450.402B	12.7	28.6	25.4	1,147	573.5	365	415	473	982	1,138	1,465	658	1,288	1,615	77
DTM 1990.402B	15.8	28.6	25.4	1,147	573.5	365	415	473	982	1,138	1,465	658	1,288	1,615	88
DTM 2250.403B	15.8	28.6	25.4	1,707	569.0	365	415	473	982	1,138	2,025	658	1,288	2,175	112
DTM 3120.403B	19.0	34.9	25.4	1,707	569.0	365	415	473	982	1,138	2,025	658	1,288	2,175	126
DTM 3830.404B	22.2	34.9	25.4	2,267	566.8	365	415	473	982	1,138	2,585	658	1,288	2,735	175
DTM 4280.404B	22.2	34.9	25.4	2,267	566.8	365	415	473	982	1,138	2,585	658	1,288	2,735	190

Model	Connection Details			Dimensional Details (mm)										Weight (Kg)*	
	Connection (mm)			A	B	H	H1	H2	C	W	L	H2*	W*		L*
	Liquid	Suction	Drain Pipe												
DTM 1760.501B	12.7	22.2	25.4	925	-	425	467	541	1,142	1,305	1,235	726	1,455	1,385	118
DTM 2650.502B	15.8	28.6	25.4	1,445	722.5	425	467	541	1,142	1,305	1,755	726	1,455	1,905	160
DTM 3250.502B	19.0	28.6	25.4	1,445	722.5	425	467	541	1,142	1,305	1,755	726	1,455	1,905	172
DTM 3770.502B	19.0	34.9	25.4	1,445	722.5	425	467	541	1,142	1,305	1,755	726	1,455	1,905	184
DTM 4520.503B	22.2	34.9	25.4	2,125	708.4	425	467	541	1,142	1,305	2,435	726	1,455	2,585	235
DTM 5370.503B	22.2	41.3	25.4	2,125	708.4	425	467	541	1,142	1,305	2,435	726	1,455	2,585	253
DTM 6170.504B	22.2	41.3	25.4	2,825	706.3	425	467	541	1,142	1,305	3,135	726	1,455	3,285	301
DTM 8670.504B	22.2	41.3	25.4	2,825	706.3	425	467	541	1,142	1,305	3,135	726	1,455	3,285	349

*Packed Dimensions / Weight

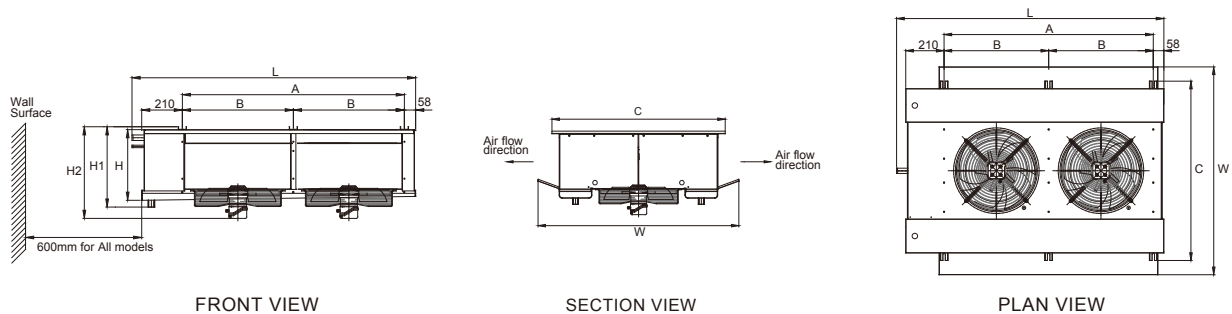

Additional Information

Application & Correction Factor Guideline (-5°C ET)

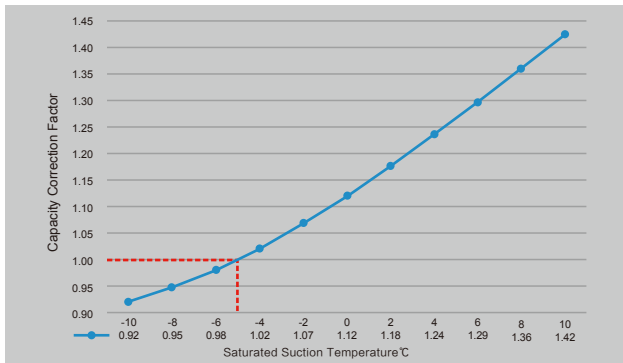

DTM Correction Chart

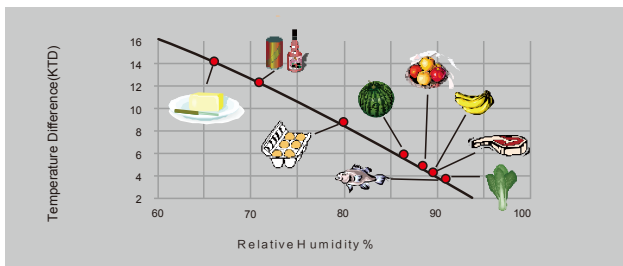

Relative Humidity %RH vs KTD

Refrigerant	Capacity Multiplier
R22	1.011
R407B	0.961
R407C	0.940
R134A	0.986
R404A / R507	1
R407F	1.011
R448A	1.030
R449A	0.930

Example (-5°C ET)

Application: Hyphae breeding Room (Mushroom Cultivation)
 Type of Refrigerant: R134A
 Calculated Cooling Capacity: 4.9 kW (Inclusive of the fan and heater load)
 Required Room Temperature: 5°C
 Required Room Humidity: 94%
 Based on %RH Vs KTD Chart on Page 5, 2KTD is required to achieve 94% RH; thus
 Evaporating Temperature (SST): 3°C (Required Room Temp minus 2KTD)

Example (-5°C ET)

Application: Processing Room
 Type of Refrigerant: R22
 Calculated Cooling Capacity: 18.5 kW (Inclusive of the fan and heater load)
 Required Room Temperature: +12°C
 Required Room Humidity: 87%
 Based on %RH Vs KTD Chart on Page 5, 6KTD is required to achieve 87% RH; thus
 Evaporating Temperature (SST): 6°C (Required Room Temp minus 6KTD)

Selection of the Eden G5 Unit Cooler as follow:

- Refer to Chart & Table on Page 5 to determine the following:
 - Capacity Correction Factor: 1.2 (ET/SST Correction Factor -5°C → 3°C)
 - Refrigerant Capacity Multiplier: 0.986 (R404A → R134A)
- Calculation of Required Cooling Capacity
 $4.9 \text{ kW} \div 1.2 \div 0.986 = 4.1 \text{ kW}$ (Inclusive of the fan and heater load)
- Calculate the unit cooler capacity needed at 8KTD (DTM rated at 8KTD)
 $4.1 \text{ kW} \div 2 \times 8 = 16.4 \text{ kW}$
- Hence **DTM 1990.402B** will be the selected unit cooler for the above application
 This means that **DTM 1990.402B** with rated capacity of 16.9kW for R404A, 8KTD will have the capacity of
 $16.9 \text{ kW} \times 1.2 \times 0.986 \times 2 \div 8 = 5 \text{ kW}$ (For R134A, 2KTD, ET = 3°C, RH=94%)

Selection of the Eden G5 Unit Cooler as follow:

- Refer to Chart & Table on Page 5 to determine the following:
 - Capacity Correction Factor: 1.29 (ET/SST Correction Factor -5°C → 6°C)
 - Refrigerant Capacity Multiplier: 1.011 (R404A → R22)
- Calculation of Required Cooling Capacity
 $18.5 \text{ kW} \div 1.29 \div 1.011 = 14.2 \text{ kW}$ (Inclusive of the fan and heater load)
- Calculate the unit cooler capacity needed at 8KTD (DTM rated at 8KTD)
 $14.2 \text{ kW} \div 6 \times 8 = 18.9 \text{ kW}$
- Hence **DTM 2250.403B** will be the selected unit cooler for the above application
 This means that **DTM 2250.403B** with rated capacity of 19kW for R404A, 8KTD will have the capacity of
 $19 \text{ kW} \times 1.29 \times 1.011 \times 6 \div 8 = 18.6 \text{ kW}$ (For R22, 6KTD, ET = 6°C, RH=87%)

Additional Information

Application & Correction Factor Guideline (2°C ET)

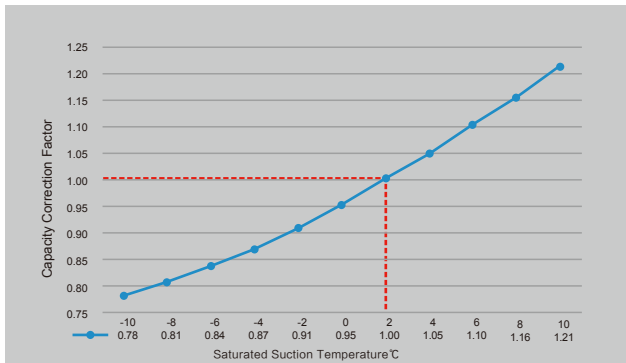

DTM Correction Chart

Refrigerant	Capacity Multiplier
R22	1.011
R407B	0.961
R407C	0.940
R134A	0.986
R404A / R507	1
R407F	1.011
R448A	1.030
R449A	0.930

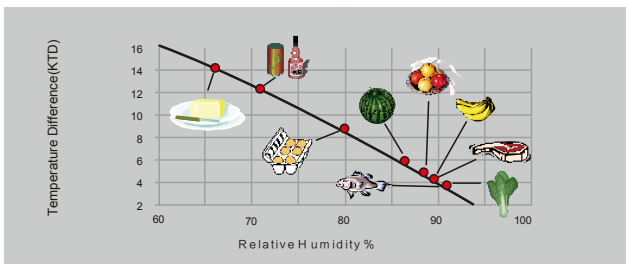

Relative Humidity %RH vs KTD

Example (2°C ET)

Application: Hyphae breeding Room (Mushroom Cultivation)
 Type of Refrigerant: R134A
 Calculated Cooling Capacity: 4.9 kW (Inclusive of the fan and heater load)
 Required Room Temperature: 5°C
 Required Room Humidity: 94%
 Based on %RH Vs KTD Chart on Page 6, 2KTD is required to achieve 94% RH; thus
 Evaporating Temperature (SST): 3°C (Required Room Temp minus 2KTD)

Example (2°C ET)

Application: Processing Room
 Type of Refrigerant: R22
 Calculated Cooling Capacity: 18.5 kW (Inclusive of the fan and heater load)
 Required Room Temperature: +12°C
 Required Room Humidity: 87%
 Based on %RH Vs KTD Chart on Page 6, 6KTD is required to achieve 87% RH; thus
 Evaporating Temperature (SST): 6°C (Required Room Temp minus 6KTD)

Selection of the Eden G5 Unit Cooler as follow:

- Refer to Chart & Table on Page 6 to determine the following:
 - Capacity Correction Factor: 1.03 (ET/SST Correction Factor 2°C → 3°C)
 - Refrigerant Capacity Multiplier: 0.986 (R404A → R134A)
- Calculation of Required Cooling Capacity
 $4.9 \text{ kW} \div 1.03 \div 0.986 = 4.8 \text{ kW}$ (Inclusive of the fan and heater load)
- Calculate the unit cooler capacity needed at 8KTD (DTM rated at 8KTD)
 $4.8 \text{ kW} \div 2 \times 8 = 19.3 \text{ kW}$
- Hence **DTM 1990.402B** will be the selected unit cooler for the above application
 This means that **DTM 1990.402B** with rated capacity of 19.9kW for R404A, 8KTD will have the capacity of
 $19.9 \text{ kW} \times 1.03 \times 0.986 \times 2 \div 8 = 5 \text{ kW}$ (For R134A, 2KTD, ET = 3°C, RH=94%)

Selection of the Eden G5 Unit Cooler as follow:

- Refer to Chart & Table on Page 6 to determine the following:
 - Capacity Correction Factor: 1.10 (ET/SST Correction Factor 2°C → 6°C)
 - Refrigerant Capacity Multiplier: 1.011 (R404A → R22)
- Calculation of Required Cooling Capacity
 $18.5 \text{ kW} \div 1.10 \div 1.011 = 16.6 \text{ kW}$ (Inclusive of the fan and heater load)
- Calculate the unit cooler capacity needed at 8KTD (DTM rated at 8KTD)
 $16.6 \text{ kW} \div 6 \times 8 = 22.2 \text{ kW}$
- Hence **DTM 2250.403B** will be the selected unit cooler for the above application
 This means that **DTM 2250.403B** with rated capacity of 22.5kW for R404A, 8KTD will have the capacity of
 $22.5 \text{ kW} \times 1.10 \times 1.011 \times 6 \div 8 = 18.8 \text{ kW}$ (For R22, 6KTD, ET = 6°C, RH=87%)