

G5 MEDIUM PROFILE UNIT COOLER

ESN / ESL



Capacity

3.45kw to 28.1kw

Effective Air Throw

18.5m to 21.1M



01

G5MEDIUM PROFILE SERIES
UNIT COOLER**G5****MEDIUM PROFILE SERIES****UNIT COOLER****ESN / ESL**

General Features

Coils are designed with the Latest Smart Circuitry. It allows maximum massflow rate of refrigerant to be evenly distributed throughout the evaporator, maximizing coil efficiency thus providing higher efficiency and capacity with a smaller physical unit cooler dimension.

Copper Tubes are accordance with JIS. C12T. Inner Groove Tube (IGT) increases the internal coil surface, having a low oil film coefficient thus providing higher efficiency and capacity.

Casing comes in high quality powder coated Aluminum, according to AA 1100 Standard. Centre plates are built in to enhance air side performance and structural strength for models with 2 or more fans.

Compact design reduces unit cooler volume to enhance cold room productivity by not giving up the capacity.

Defrosting is by electrical sheathed stainless steel heater elements fitted with molded insulated connection and ultra low temperature silicone leads (rated to -80°C), to ensure effective defrosting and durability. Water resulting from defrosting is channeled to the drain pan with a centrally positioned outlet for positive draining from all points.

Fins are produced from high-grade Aluminum (Aluminum Association -AA 1100 Standard) with Double Sine Wave Pattern and Rippled Fin Edges to provide higher heat transfer efficiency.

Fan Motors used in all the models are high quality Breeze fan motors. Fan motors are of the highest quality offered in the industry ensuring long life and durability for both high and low temperature application. Junction box hidden is for protection of the conductors.

Both side panels with hinges, created to allow for easy access and service of components without removing the panels.

Capacity Ratings are thermally guaranteed by Eden and tested in accordance to ASHRAE dry box standards.

Quality Assurance for all Eden products are designed, manufactured and tested in our factories that are ISO9001 certified.

One Year Warranty for all Eden Heat Exchanger products (Terms and conditions apply).



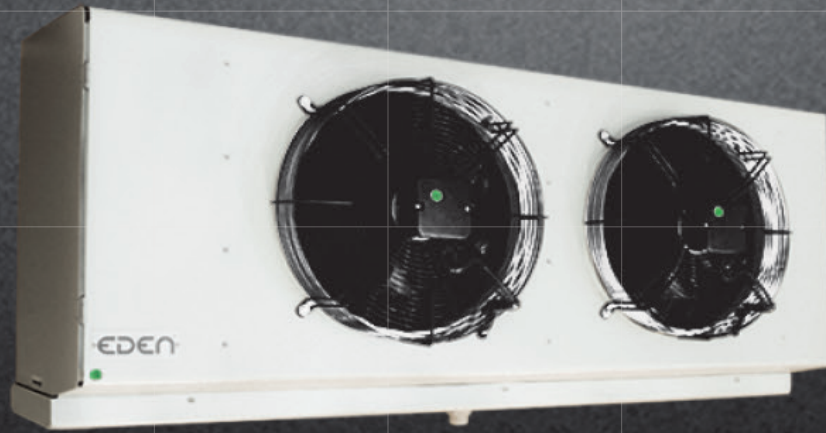

Options

- a** Copper-Fins Coil (Available only for 4FPI to 6FPI)
- b** Epoxy-Coated Aluminum Fin Coil (Only on large volume orders)
- c** Hot Gas Bypass
- d** Dual Fins (Staggered Fins)
- e** Stainless Steel Casing
- f** Special Circuitry For Ultra Low Temperature Or Overfeed Systems
- g** Chilled Water Coils, Brine Coils Or Liquid Overfeed Coils On Most Models

Nomenclature

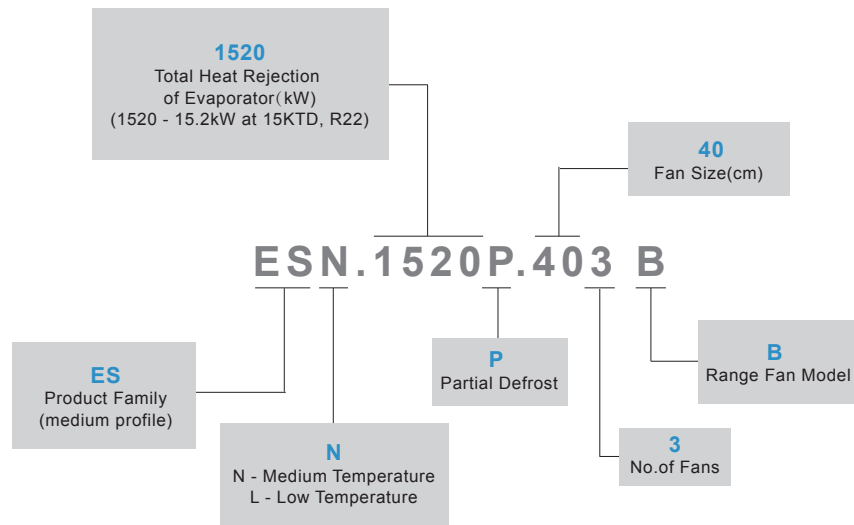

Technical Data

ESN-Medium Profile Series Unit

Air Defrost 6FPI Room Temperature +3° C

Model	Capacity R22				No. of Fans 400mm	Fan Data						
	ASHRAE		EUROVENT SC2*			Fan Motor			Fan	Air Flow		Air Throw (m)
	Watts	Btu/hr	Watts	Btu/hr		(V/Ph/Hz)	(Watts)	(Amps)	(rpm)	(L/s)	(m³/h)	
ESN 0345.401B	3,450	11,772	3,767	12,855	1	400/3/50	190	0.5	1350	830	2988	19.4
ESN 0506.401B	5,060	17,265	5,526	18,853	1	400/3/50	190	0.5	1350	830	2988	19.2
ESN 0641.401B	6,410	21,872	7,000	23,884	1	400/3/50	190	0.5	1350	830	2988	19.0
ESN 0750.401B	7,500	25,591	8,190	27,945	1	400/3/50	190	0.5	1350	830	2988	18.8
ESN 0839.401B	8,390	28,628	9,162	31,262	1	400/3/50	190	0.5	1350	830	2988	18.5
ESN 0985.402B	9,850	33,610	10,756	36,702	2	400/3/50	380	1.0	1350	1650	5940	19.7
ESN 1243.402B	12,430	42,413	13,574	46,315	2	400/3/50	380	1.0	1350	1650	5940	19.5
ESN 1456.402B	14,560	49,681	15,900	54,252	2	400/3/50	380	1.0	1350	1650	5940	19.2
ESN 1705.402B	17,050	58,177	18,619	63,529	2	400/3/50	380	1.0	1350	1650	5940	19.0
ESN 1925.403B	19,250	65,684	21,021	71,727	3	400/3/50	570	1.5	1350	2480	8928	20.2
ESN 2328.403B	23,280	79,435	25,422	86,743	3	400/3/50	570	1.5	1350	2480	8928	20.0
ESN 2670.403B	26,700	91,104	29,156	99,486	3	400/3/50	570	1.5	1350	2480	8928	19.7
ESN 2850.404B	28,500	97,246	31,122	106,193	4	400/3/50	760	2.0	1350	3300	11880	20.7
ESN 3282.404B	32,820	111,987	35,839	122,290	4	400/3/50	760	2.0	1350	3300	11880	20.5
ESN 3670.404B	36,700	125,226	40,076	136,747	4	400/3/50	760	2.0	1350	3300	11880	20.3
ESN 4144.405B	41,440	141,399	45,252	154,408	5	400/3/50	950	2.5	1350	4150	14940	21.3
ESN 4520.405B	45,200	154,229	49,358	168,418	5	400/3/51	950	2.5	1350	4150	14940	21.1

Application & Correction Factor Guideline

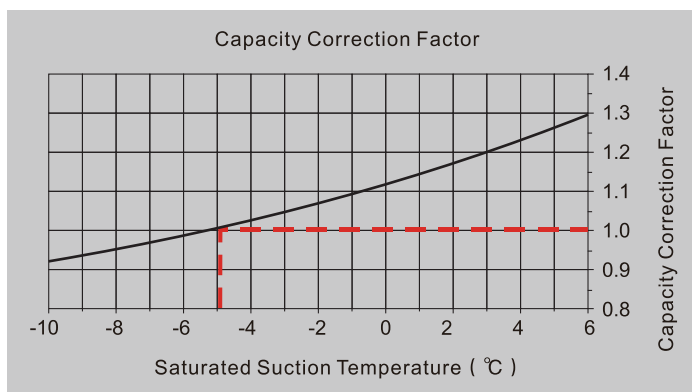

Refrigerant	Capacity Multiplier
R22	1.00
R407B	0.95
R407C	0.93
R134A	0.975
R404A	0.989
R507	0.989
R407F	1.00

Capacity Ratings & Conditions

All Eden Heat Exchangers are tested in Accordance to ASHRAE Dry Box Standard. (Recommended for Asia Usage)

* EUROVENT Data is used for Comparison Purposes

* EUROVENT Data is based on SC2 Nominal Capacity

SC2 Condition - Air Inlet Temperature = 0°C and Evaporating Temperature = -8°C

Technical Data

ESN-Medium Profile Series Unit

Electric Defrost 6FPI Room Temperature -4° C

Model	Capacity R22				No. of Fans 400mm	Fan Data						Heater Data		
	ASHRAE		EUROVENT SC2*			Fan Motor			Fan Speed	Air Flow		Air Throw (m)	Coil Heater (Watts)	Drain Pan Heater (Watts)
	Watts	Btu/hr	Watts	Btu/hr		(V/Ph/Hz)	(Watts)	(Amps)	(rpm)	(L/s)	(m³/h)			
6 KTD	10.8	8 KTD	14.4 FTD											
ESN 0288P.401B	2,880	9,827	4,320	14,741	1	400/3/50	190	0.5	1350	830	2988	19.2	2 X 600	1 X 450
ESN 0368P.401B	3,680	12,557	5,520	18,836	1	400/3/50	190	0.5	1350	900	3240	19.0	2 X 600	1 X 450
ESN 0435P.401B	4,350	14,843	6,525	22,265	1	400/3/50	190	0.5	1350	900	3240	18.8	2 X 600	1 X 450
ESN 0491P.401B	4,910	16,754	7,365	25,131	1	400/3/50	190	0.5	1350	900	3240	18.5	2 X 600	1 X 450
ESN 0565P.402B	5,650	19,279	8,475	28,919	2	400/3/50	380	1.0	1350	1650	5940	19.7	2 X 1150	1 X 700
ESN 0719P.402B	7,190	24,533	10,785	36,800	2	400/3/50	380	1.0	1350	1650	5940	19.5	2 X 1150	1 X 700
ESN 0848P.402B	8,480	28,935	12,720	43,403	2	400/3/50	380	1.0	1350	1650	5940	19.2	2 X 1150	1 X 700
ESN 0998P.402B	9,980	34,053	14,970	51,080	2	400/3/50	380	1.0	1350	1650	5940	19.0	2 X 1150	1 X 700
ESN 1125P.403B	11,250	38,387	16,875	57,581	3	400/3/50	570	1.5	1350	2480	8928	20.2	2 X 1700	1 X 1070
ESN 1362P.403B	13,620	46,473	20,430	69,710	3	400/3/50	570	1.5	1350	2480	8928	20.0	2 X 1700	1 X 1070
ESN 1520P.403B	15,200	51,865	22,800	77,798	3	400/3/50	570	1.5	1350	2480	8928	19.7	2 X 1700	1 X 1070
ESN 1678P.404B	16,780	57,256	25,170	85,884	4	400/3/50	760	2.0	1350	3400	12240	20.7	2 X 2300	1 X 1400
ESN 1965P.404B	19,650	67,049	29,475	100,574	4	400/3/50	760	2.0	1350	3400	12240	20.5	2 X 2300	1 X 1400
ESN 2194P.404B	21,940	74,862	32,910	112,293	4	400/3/50	760	2.0	1350	3400	12240	20.3	2 X 2300	1 X 1400
ESN 2460P.405B	24,600	83,939	36,900	125,909	5	400/3/50	950	2.5	1350	4250	15300	21.3	2 X 2950	1 X 1770
ESN 2810P.405B	28,100	95,881	42,150	143,822	5	400/3/50	950	2.5	1350	4250	15300	21.1	2 X 2950	1 X 1770

Application & Correction Factor Guideline

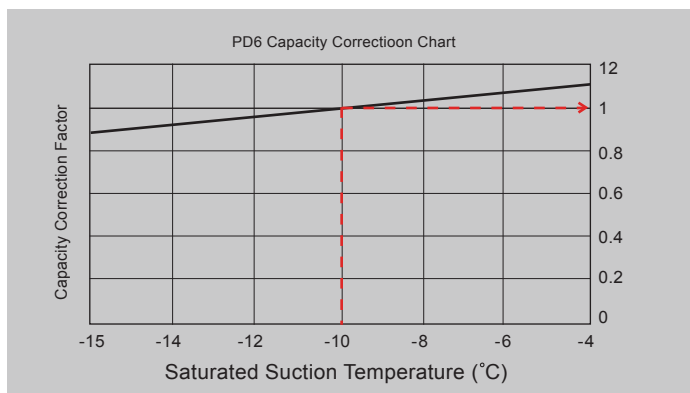

Refrigerant	Capacity Multiplier
R22	1.00
R407B	0.95
R407C	0.93
R134A	0.975
R404A	0.989
R507	0.989
R407F	1.00

Capacity Ratings & Conditions

All Eden Heat Exchangers are tested in Accordance to ASHRAE Dry Box Standard. (Recommended for Asia Usage)

* EUROVENT Data is used for Comparison Purposes

* EUROVENT Data is based on SC2 Nominal Capacity

SC2 Condition - Air Inlet Temperature = 0°C and Evaporating Temperature = -8°C

Technical Data

ESL-Medium Profile Series Unit

Electric Defrost 4FPI Room Temperature -19° C

Model	Capacity R22				No. of Fans 400mm	Fan Data						Heater Data		
	ASHRAE		EUROVENT SC3*			Fan Motor			Fan Speed	Air Flow		Air Throw (m)	Coil Heater (Watts)	Drain Pan Heater (Watts)
	Watts	Btu/hr	Watts	Btu/hr		(V/Ph/Hz)	(Watts)	(Amps)	(rpm)	(L/s)	(m³/h)			
	6 KTD	10.8	7 KTD	12.6 FTD										
ESL 0194.401B	1,940	6,620	2,367	8,076	1	400/3/50	190	0.5	1350	850	3060	19.2	4 X 600	1 X 450
ESL 0241.401B	2,410	8,223	2,940	10,032	1	400/3/50	190	0.5	1350	850	3060	19.0	4 X 600	1 X 450
ESL 0282.401B	2,820	9,622	3,440	11,739	1	400/3/50	190	0.5	1350	850	3060	18.8	4 X 600	1 X 450
ESL 0320.401B	3,200	10,919	3,904	13,321	1	400/3/50	190	0.5	1350	850	3060	18.5	4 X 600	1 X 450
ESL 0371.402B	3,710	12,659	4,526	15,444	2	400/3/50	380	1.0	1350	1700	6120	19.7	4 X 1150	1 X 700
ESL 0473.402B	4,730	16,139	5,771	19,690	2	400/3/50	380	1.0	1350	1700	6120	19.5	4 X 1150	1 X 700
ESL 0598.402B	5,980	20,405	7,296	24,894	2	400/3/50	380	1.0	1350	1700	6120	19.2	4 X 1150	1 X 700
ESL 0731.402B	7,310	24,943	8,918	30,430	2	400/3/50	380	1.0	1350	1700	6120	19.0	4 X 1150	1 X 700
ESL 0843.403B	8,430	28,764	10,285	35,092	3	400/3/50	570	1.5	1350	2550	9180	20.2	4 X 1700	1 X 1070
ESL 1010.403B	10,100	34,463	12,322	42,045	3	400/3/50	570	1.5	1350	2550	9180	20.0	4 X 1700	1 X 1070
ESL 1168.403B	11,680	39,854	14,250	48,622	3	400/3/50	570	1.5	1350	2550	9180	19.7	4 X 1700	1 X 1070
ESL 1296.404B	12,960	44,221	15,811	53,950	4	400/3/50	760	2.0	1350	3400	12240	20.7	4 X 2300	1 X 1400
ESL 1489.404B	14,890	50,807	18,166	61,985	4	400/3/50	760	2.0	1350	3400	12240	20.5	4 X 2300	1 X 1400
ESL 1624.404B	16,240	55,413	19,813	67,604	4	400/3/50	760	2.0	1350	3400	12240	20.3	4 X 2300	1 X 1400
ESL 1945.405B	19,450	66,366	23,729	80,967	5	400/3/50	950	2.5	1350	4250	15300	21.3	4 X 2950	1 X 1770
ESL 2177.405B	21,770	74,282	26,559	90,624	5	400/3/50	950	2.5	1350	4250	15300	21.1	4 X 2950	1 X 1770

Application & Correction Factor Guideline

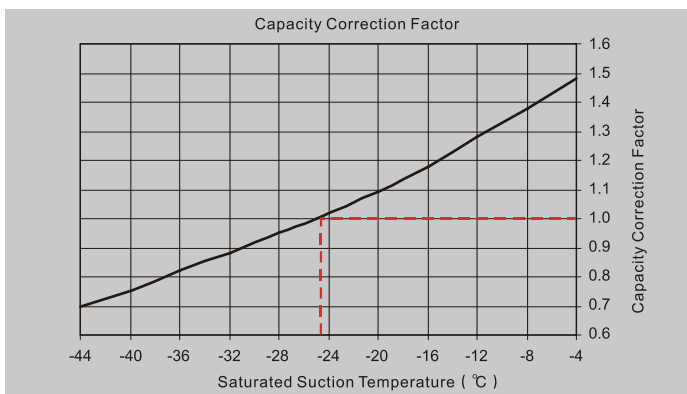

Refrigerant	Capacity Multiplier
R22	1.00
R407B	0.95
R407C	0.93
R134A	0.975
R404A	0.989
R507	0.989
R407F	1.00

Capacity Ratings & Conditions

All Eden Heat Exchangers are tested in Accordance to ASHRAE Dry Box Standard. (Recommended for Asia Usage)

* EUROVENT Data is used for Comparison Purposes

* EUROVENT Data is based on SC3 Nominal Capacity

SC3 Condition - Air Inlet Temperature = -18°C and Evaporating Temperature = -25°C

Dimension

ESL / ESN / ESN PD6

Model	Size (mm)								Weight (kg)*	Liquid Connection (mm)	Suction Connection (mm)	Drain Pipe (mm)
	A	B	H	W	L	H *	W *	L *				
ESN 0345.401B	588	-	639	330	957	820	620	1100	25	12.7	22.2	25.4
ESN 0506.401B	588	-	639	330	957	820	620	1100	27	12.7	22.2	25.4
ESN 0641.401B	588	-	639	330	957	820	620	1100	29	12.7	28.6	25.4
ESN 0750.401B	588	-	639	330	957	820	620	1100	31	12.7	28.6	25.4
ESN 0839.401B	588	-	639	330	957	820	620	1100	34	12.7	28.6	25.4
ESN 0985.402B	1148	574 (x2)	639	330	1517	820	620	1660	48	12.7	28.6	25.4
ESN 1243.402B	1148	574 (x2)	639	330	1517	820	620	1660	52	12.7	28.6	25.4
ESN 1456.402B	1148	574 (x2)	639	330	1517	820	620	1660	57	15.8	28.6	25.4
ESN 1705.402B	1148	574 (x2)	639	330	1517	820	620	1660	61	15.8	28.6	25.4
ESN 1925.403B	1707	569 (x3)	639	330	2077	820	620	2220	78	15.8	28.6	25.4
ESN 2328.403B	1707	569 (x3)	639	330	2077	820	620	2220	84	19.0	34.9	25.4
ESN 2670.403B	1707	569 (x3)	639	330	2077	820	620	2220	91	19.0	34.9	25.4
ESN 2850.404B	2268	567 (x4)	639	330	2637	820	620	2790	117	19.0	34.9	25.4
ESN 3282.404B	2268	567 (x4)	639	330	2637	820	620	2790	128	22.2	34.9	25.4
ESN 3670.404B	2268	567 (x4)	639	330	2637	820	620	2790	140	22.2	34.9	25.4
ESN 4144.405B	2830	566 (x5)	639	330	3198	820	620	3350	158	22.2	41.3	25.4
ESN 4520.405B	2830	566 (x5)	639	330	3198	820	620	3350	173	22.2	41.3	25.4
ESN 0288P.401B	588	-	639	330	957	820	620	1100	27	12.7	22.2	25.4
ESN 0368P.401B	588	-	639	330	957	820	620	1100	29	12.7	22.2	25.4
ESN 0435P.401B	588	-	639	330	957	820	620	1100	31	12.7	22.2	25.4
ESN 0491P.401B	588	-	639	330	957	820	620	1100	34	12.7	22.2	25.4
ESN 0565P.402B	1148	574 (x2)	639	330	1517	820	620	1660	48	12.7	22.2	25.4
ESN 0719P.402B	1148	574 (x2)	639	330	1517	820	620	1660	52	12.7	28.6	25.4
ESN 0848P.402B	1148	574 (x2)	639	330	1517	820	620	1660	57	15.8	28.6	25.4
ESN 0998P.402B	1148	574 (x2)	639	330	1517	820	620	1660	61	15.8	28.6	25.4
ESN 1125P.403B	1707	569 (x3)	639	330	2077	820	620	2220	78	15.8	28.6	25.4
ESN 1362P.403B	1707	569 (x3)	639	330	2077	820	620	2220	84	19.0	28.6	25.4
ESN 1520P.403B	1707	569 (x3)	639	330	2077	820	620	2220	91	19.0	28.6	25.4
ESN 1678P.404B	2268	567 (x4)	639	330	2637	820	620	2790	117	19.0	28.6	25.4
ESN 1965P.404B	2268	567 (x4)	639	330	2637	820	620	2790	128	22.2	34.9	25.4
ESN 2194P.404B	2268	567 (x4)	639	330	2637	820	620	2790	140	22.2	34.9	25.4
ESN 2460P.405B	2830	566 (x5)	639	330	3198	820	620	3350	158	22.2	34.9	25.4
ESN 2810P.405B	2830	566 (x5)	639	330	3198	820	620	3350	173	22.2	34.9	25.4
ESL 0194.401B	588	-	639	330	957	820	620	1100	27	12.7	22.2	25.4
ESL 0241.401B	588	-	639	330	957	820	620	1100	29	12.7	22.2	25.4
ESL 0282.401B	588	-	639	330	957	820	620	1100	31	12.7	22.2	25.4
ESL 0320.401B	588	-	639	330	957	820	620	1100	33	12.7	22.2	25.4
ESL 0371.402B	1148	574 (x2)	639	330	1517	820	620	1660	48	12.7	22.2	25.4
ESL 0473.402B	1148	574 (x2)	639	330	1517	820	620	1660	52	12.7	28.6	25.4
ESL 0598.402B	1148	574 (x2)	639	330	1517	820	620	1660	56	15.8	28.6	25.4
ESL 0731.402B	1148	574 (x2)	639	330	1517	820	620	1660	60	15.8	28.6	25.4
ESL 0843.403B	1707	569 (x3)	639	330	2077	820	620	2220	78	15.8	28.6	25.4
ESL 1010.403B	1707	569 (x3)	639	330	2077	820	620	2220	84	19.0	28.6	25.4
ESL 1168.403B	1707	569 (x3)	639	330	2077	820	620	2220	90	19.0	28.6	25.4
ESL 1296.404B	2268	567 (x4)	639	330	2637	820	620	2790	116	19.0	28.6	25.4
ESL 1489.404B	2268	567 (x4)	639	330	2637	820	620	2790	127	22.2	34.9	25.4
ESL 1624.404B	2268	567 (x4)	639	330	2637	820	620	2790	138	22.2	34.9	25.4
ESL 1945.405B	2830	566 (x5)	639	330	3198	820	620	3350	157	22.2	34.9	25.4
ESL 2177.405B	2830	566 (x5)	639	330	3198	820	620	3350	171	22.2	34.9	25.4

*Packed Dimensions / Weight

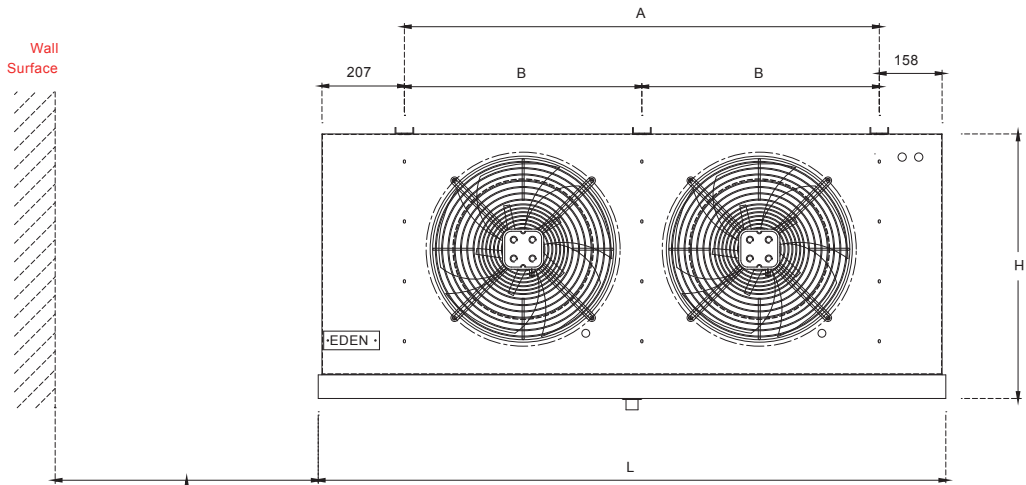

FRONT VIEW

520MM FOR 1 FAN MOTOR
 540MM FOR 2 FANS MOTOR
 560MM FOR 3 FANS MOTOR
 580MM FOR 4 FANS MOTOR
 600MM FOR 5 FANS MOTOR

(A) INDUCED DRAUGHT COOLING UNIT

(B) FORCED DRAUGHT COOLING UNIT

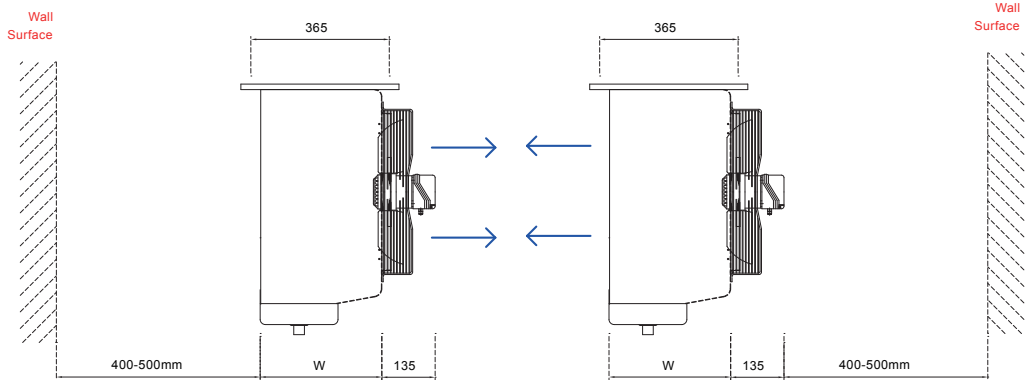

SIDE VIEW

SIDE VIEW

ADDITIONAL INFORMATION

Example:

Application: Apple Cooler
Required Room Temperature: 1.5°C
Ambient: +35°C
Evaporating Temperature: -3.5°C at 5KTD (Recommended)
Cooling Capacity: 4.3kW (Inclusive of the Fan and Heater load)
Type of Refrigerant: R22

Selection of the Eden G4 Unit Cooler as follow:

- 1 Determine the Correction Factors and Multiplier (Refers to page3):
 - a. Capacity Correction Factor is approx. 1.04
 - b. Refrigerant multiplier = 1
- 2 Calculation of required Capacity:
 - a. $4.3\text{kW} / 1.04 / 1 = 4.13\text{kW}$ (Inclusive of the Fan and Heater load)
- 3 Calculate the unit cooler Capacity needed at 5KTD
 - a. $4.13 \times 8 / 5 = 6.61\text{kW}$
- 4 Hence a **ESN 0750.401B** is the suitable unit cooler for the above application.

